

## MINIROLL

Technical data		3-row	4-row	5-row (option)
Dimensions (L x W x H) (cladding parts may protrude beyond the basic dimensions by 100 mm)	mm	3,000 x 1,110 x 2,150		
Required ceiling height	mm	2,200		
Hourly capacity	pieces/hour	1,800	2,400	3,000
Capacity in green mode	pieces/hour	4,500	6,000	7,500
Pre-proofing time	min.	6		
Weight range		35 g to 90 g (35 g to 150 g optional)		
Weight range double rolls (via bypass belt and double loading)		2 x 55 g to 2 x 90 g		
Weight range via bypass belt		35 g to 90 g (35 g to 150 g optional)		
Proofing board dimensions	mm	400 x 600 // 580 x 780 // 580 x 980		
Connected load		4.5 kW / 3 x 400 V		

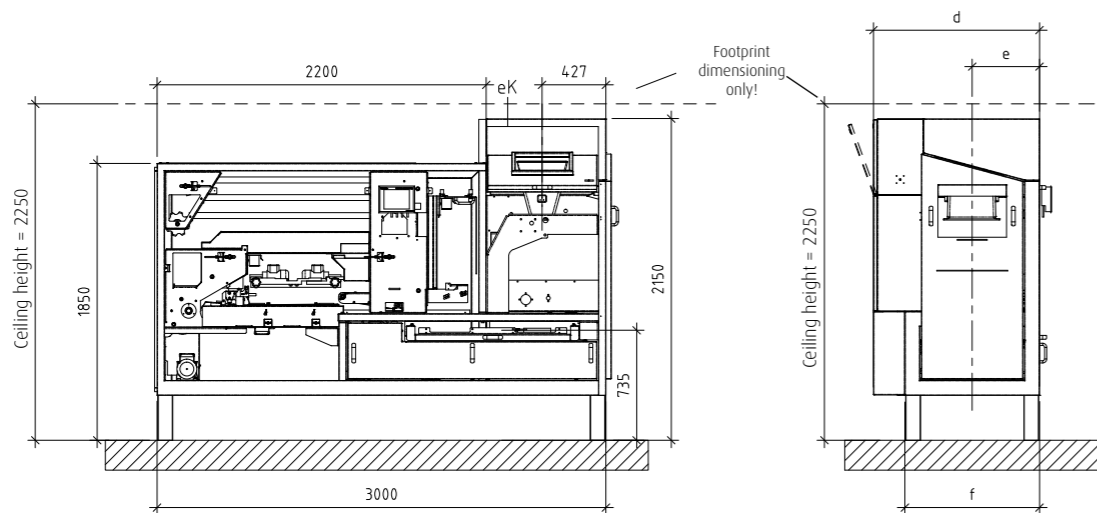

**WP BAKERY GROUP USA**  
2 Trap Falls Road, Suite 105, Shelton, CT 06484 | PH: 203-929-6530 | FX: 203-929-7089  
info@wpbakerygroupusa.com | www.wpbakerygroupusa.com



## MINIROLL

The compact roll baking system with high capacity in the smallest space



# MINIROLL



## WP CleanTec

- Hygiene concept



## WP SmartControl

- Easy operation



## WP GreenEnergy

- Energy-efficient line operation



## WP BakingQuality

- Product-specific conditioning gentle on the dough



**COMPACT BAKING SYSTEM FOR SMALL BAKERY ITEMS WITH INTEGRATED DRUM MOULDER FOR THE PRODUCTION OF**

- LONG-ROLLED ROLLS
- SMOOTH ROUND ROLLS
- HAMBURGER BUNS
- CYLINDRICAL ROLLS
- DOUBLE ROLLS

**WITHIN A WEIGHT RANGE OF 35 G TO 90 G (35 G TO 150 G OPTIONAL)**

## SPECIFICATION

- 4-row line with 600 mm working width
- Integrated drum moulder with rotary valve
- Interchangeable chamber drum (1 chamber drum of your choice)
- Manual pressure adjustment
- Adjustable moulding belt
- Long roller with 1 pressure board
- Pre-proofing time 6 min
- Ribbon drying
- Maintenance-free ribbon chain with automatic tensioning
- Climate correction
- Variable depositing unit for proofing boards in 3 Euro sizes, 400 x 600 / 580 x 780 / 580 x 980
- Intensive degermination station

## OPTIONS

- 5-row dough divider
- Pressure roller on spreading belt
- Pressure roller on long roller
- Folding flap
- Driven top belt
- Pressure board continuous
- Pressure board double, triple, quadruple
- Bypass belt (for green mode)
- On wheels for sideway movement of the line
- Elevation of legs by 50 mm or 100 mm

## BENEFITS

- Small bakery items in perfect craftsmanship quality
- Integrated drum moulder with proven Multimatic dividing principle
- Space-saving compact design
- Product diversity thanks to
  - interchangeable pressure boards
  - driven top belt
- WP NAVIGO II PROFI-CONTROL control system
  - simple operation
  - reproducible quality
- Bypass belt (green mode) for direct conditioning without proofing cabinet
- Use of commercially available proofing boards thanks to the variable program-controlled depositing unit
- Hygienic safety thanks to
  - intensive degermination station
  - stainless steel design
  - removable dough-handling parts for cleaning

