

CCR 69 AT

TYPE	WEIGHT RANGE	CAPACITY
K	270 - 700 gr	maximum 10.000 pcs/h.,
M	350 - 1100 gr	depending on execution

DIMENSIONS		WEIGHT	CONNECTED LOAD
Length	1609 mm	nett 2240 kg	230/400 V 3 ph 50 Hz + earth
Width	1663 mm	gross 2340 kg	4 KVA
Height	1729 mm	Shipping volume 5.0 m ³	

OPTIONS

- Blower on cone and tracks
- Oiling device on cone for handling soft doughs
- Two way pneumatic flipper gate
- Customer specific Blue Box

WP BAKERY GROUP USA

2 Trap Falls Road, Suite 105, Shelton, CT 06484 // Phone 203-929-6530 // Fax 203-929-7089 // info@wpbakerygroupusa.com // www.wpbakerygroupusa.com



CCR 69 AT

Industrial Rounder

CCR 69 AT

Picture CCR 69 AT

INDUSTRIAL ROUNDER USED IN INDUSTRIAL DOUGH LINES WITH A HIGH CAPACITY UP TO 10.000 PCS/H AND LONG PRODUCTION HOURS. THE MACHINE IS SUITABLE FOR MANY COMMON DOUGH TYPES, SUCH AS STIFF AND SOFT WHEAT DOUGHS AND WHEAT / RYE DOUGHS.



BENEFITS

- Cylindrical/conical rounder
- Maximum 6 meter round moulding length
- Cone with big diameter; large distance between dough pieces to avoid doubles
- All parts in contact with dough are dough repellent
- Cone speed adjustable
- Tracks, individual adjustable
- Robust construction
- All frame parts in stainless steel
- Excellent round moulding results at high capacity
- Easy control and maintenance

BASIC EXECUTION:

- Cast iron cylinder/cone, Teflon coated
- Aluminium tracks, in- and outside Teflon coated
- Discharge roller, adjustable
- Discharge conveyor L=500 mm
- Drive unit consisting of electric motor with frequency inverter
- Cylindrical/cone rotates clockwise
- Undercarriage nickel steel with 4 castors, dowel pins and blocking
- With operation control panel

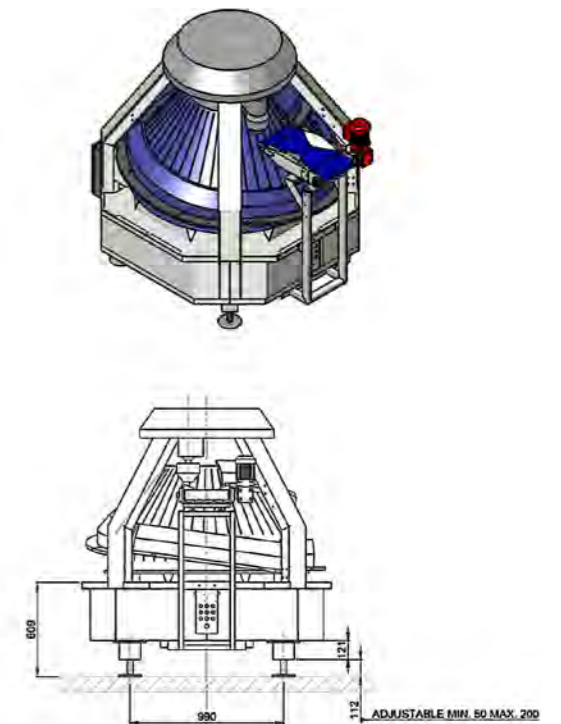
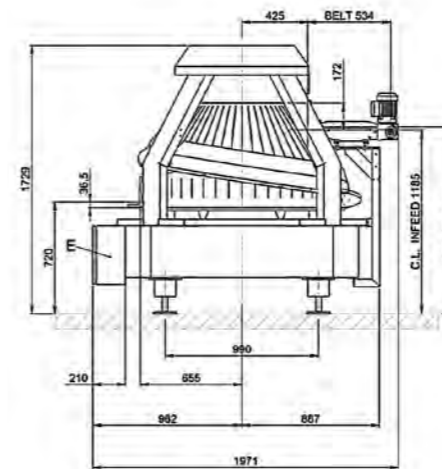
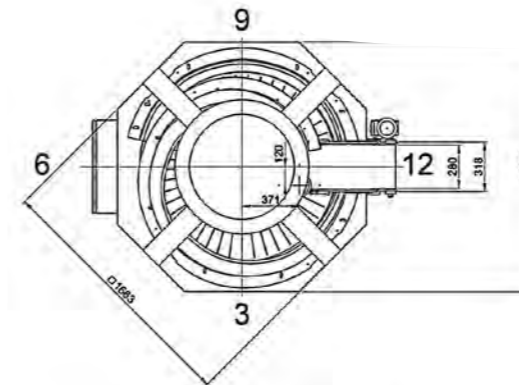

Illustration CCR 69 AT