

B / V 300

TYPE	WEIGHT RANGE	CAPACITY (FIXED)	CAPACITY VARIABLE (OPTION)
1000	100 - 1200 gr	910 or 1010 pcs/h.	507-1160 / 637-1456 / 700-1600 pcs/h.
1500	200 - 1800 gr	910 or 1010 pcs/h.	507-1160 / 637-1456 / 700-1600 pcs/h.
2000	400 - 2400 gr	910 or 1010 pcs/h.	507-1160 / 637-1456 / 700-1600 pcs/h.

DIMENSIONS (DEPENDING ON EXECUTION)		WEIGHT	CONNECTED LOAD
Length	1506 mm	net 720 kg	230/400 V, 3 ph, 50 Hz + earth
Width	1001 mm	gross 880 kg	1,8 KVA
Height	1711 mm	Shipping volume 2,6 m ³	

OPTIONS

- Hopper 150 ltr., 180 ltr.
- Hopper inside Teflon coated for round hoppers 95 and 150 ltr.
- Oiling on hopper
- Pre-set counter
- Frequency inverter for variable speed
- Discharge conveyor straight, 1885 or 2185 mm
- Position stop
- Mechanical discharge flap
- Weight adjustment with Servo motor
- Oil shortage signal
- Beka pump 8 P
- Mechanical flour duster
- Pressure board on conveyer
- Oiling on measuring piston
- Increasing the machine with 100 mm
- Seyel panel - digital display
- Customer specific Blue Box

EXTRA OPTION, ONLY FOR THE V 300

- Pneumatic discharge flap

WP BAKERY GROUP USA

2 Trap Falls Road, Suite 105, Shelton, CT 06484 // Phone 203-929-6530
 Fax 203-929-7089 // info@wpbakerygroupusa.com // www.wpbakerygroupusa.com



B / V 300

Dough Divider

B / V 300

Picture B 300

SUITABLE FOR MOST COMMON TYPES OF DOUGH AS WELL AS SENSITIVE DOUGHS SUCH AS WHEAT, WHEAT/RYE, STIFF (PIZZA) DOUGHS, AS WELL AS SOFT (FRENCH) DOUGHS.



BASIC EXECUTION:

B 300

- Dividing unit with automatic oiling, 6 fixed dosing valves / oil tank 5 ltr.
- Conveyor straight, L=1435 mm
- Hopper, stainless steel, 95 ltr., with safety ring
- Operation: on / off / emergency stop
- Main piston, dividing chamber and hopper: wear-resistant chrome nickel alloy
- Measuring pistons bronze
- Knife hardened steel
- Cover plates, stainless steel, brushed, with Schmersal safety switches
- Frame: steel, nickel coated
- Crankshaft and drive rods cast iron, nickel coated

V 300

- Voluminator
- Dividing unit with automatic oiling, 8 fixed dosing valves / oil tank 5 ltr.
- Conveyor straight, L=1685 mm
- Mechanical discharge flap with plastic scraper
- Hopper, stainless steel, 95 ltr., with safety ring
- Operation: on / off / emergency stop
- Main piston, dividing chamber and hopper: wear-resistant chrome nickel alloy
- Measuring pistons bronze
- Knife hardened steel
- Cover plates, stainless steel, brushed, with Schmersal safety switches
- Frame: steel, nickel coated
- Crankshaft and drive rods cast iron, nickel coated
- Stop position

BENEFITS

- Robust design
- Long lifespan by using wear-resistant materials
- Minimum oil consumption
- High weight precision
- Dough friendly dividing
- Self-cleaning knife
- Round dough hopper neck
- Hinged dough hopper for easy cleaning
- Voluminator (V 300 only) with low and high pressure setting
- Good handling of practical all common dough types
- Easy access for cleaning and maintenance

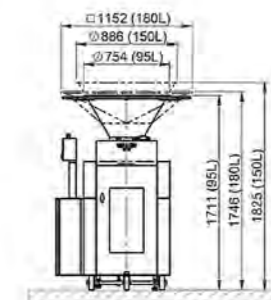
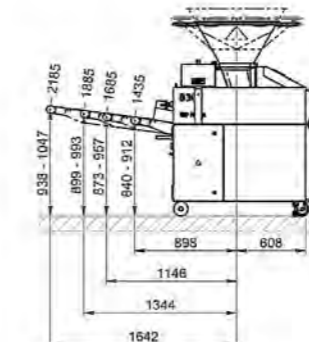
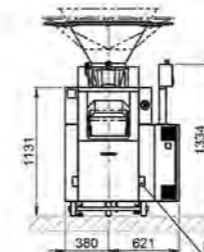
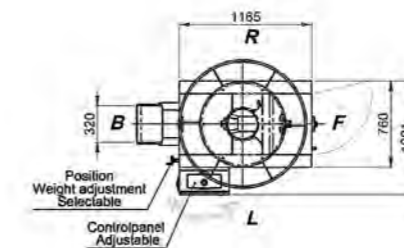
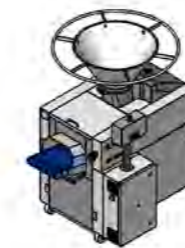

Illustration B 300