

B 700

TYPE	PARTITIONS	WEIGHT RANGE	CAPACITY
B 700-2	25 / 50 mm	400 - 2400 / 400-2100 gr	1000-3000 pcs/h.
B 700-3	25 mm	300 - 1400 gr	1500-4500 pcs/h.
B 700-4	25 mm	200 - 1000 gr	2000-6000 pcs/h.
B 700-4-split	2x L / 2x R - 25 mm	150 - 1000 gr	2500-6000 pcs/h.
B 700-5	25 mm	150 - 780 gr	2500-7500 pcs/h.
B 700-6	25 mm	150 - 600 gr	3000-9000 pcs/h.
B 700-6-split	3x L / 3x R - 25 mm	150 - 600 gr	3000-9000 pcs/h.
B 700-8	16 mm	50 - 200 gr	4000-9600 pcs/h.
B 700-2/4	25 mm	400 - 2150 / 200 - 925 gr	1000-3000 / 2000-6000 pcs/h.
B 700-3/6	25 mm	300 - 1300 / 150 - 520 gr	1500-4500 / 3000-9000 pcs/h.
DIMENSIONS (DEPENDING ON EXECUTION)		WEIGHT	CONNECTED LOAD
Length	2961 mm	net 1550 kg	230/400 V, 3 ph, 50 Hz + earth
Width	1647 mm	gross 1720 kg	3 KVA
Height	2056 mm	Shipping volume 3,7 m ³	

OPTIONS

- Hopper inside Teflon coated 120, 160, 250 ltr.
- Hopper inside HDPE material
- Oiling on hopper
- Discharge conveyor 500 mm, lengthening possible per 100 mm up to 1500 mm
- SR unit
- Flour duster with independent drive
- Belts, felt
- Oil catch pan under machine, movable
- Connection for Checkweigher
- Curling net on discharge conveyor
- Allen Bradley controls
- Increasing the machine with 100 mm
- Customer specific Blue Box

WP BAKERY GROUP USA

2 Trap Falls Road, Suite 105, Shelton, CT 06484 // Phone 203-929-6530 // Fax 203-929-7089 // info@wpbakerygroupusa.com // www.wpbakerygroupusa.com



B 700

Dough Divider

B 700

Picture B 700 with rounder CCR 59 and OCS Checkweigher

SUITABLE FOR ALL COMMON DOUGH TYPES SUCH AS WHEAT, WHEAT/RYE, MULTI GRAIN, WHOLE WHEAT DOUGHS, AS WELL FOR STIFF PIZZA DOUGHS AS FOR SOFT (FRENCH) DOUGHS.



BENEFITS

- High weight accuracy
- Robust design
- Large weight range
- Frame out of rectangular, nickel coated tubular profiles for easy access
- Open front design for visual control on discharge conveyor side
- Wear resistant dividing system with dividing unit in Ni-Resist
- Solid construction of drive system and dividing mechanism
- High pressure oiling system, for minimum use of oil
- Operation by means of touch screen
- Automatic version with possibility for weight correction by means of a Checkweigher

BASIC EXECUTION:

- B 700 : 2, 3, 4, 4-split, 5, 6, 6-split, 8, 2/4, 3/6 pocket machine
- Dividing unit Ni-Resist with automatic oiling with 6 fixed and 14 adjustable metering valves, oil tank 10 ltr.
- Oiling on conveyor
- Discharge conveyor 500 mm., with quick-lock system, scraper and catch tray
- Separate drive on in- and outside conveyor with drum motors incl. frequency inverter
- Pneumatic discharge flap with plastic scraper
- Hopper stainless steel, inside Teflon coated, 70 ltr.
- Hopper base Teflon coated
- Frequency inverter for variable speed
- Operation by means of touch screen
- Discharge flap and positioning roller controlled from touch screen
- Main piston Ni-Resist
- Automatic switch of in case of no oil
- Measuring pistons bronze
- Knife hardened steel
- Cover plates, stainless steel, brushed, with Schmersal safety switches
- Frame: steel, nickel coated
- Crankshaft and drive rods cast iron, nickel coated

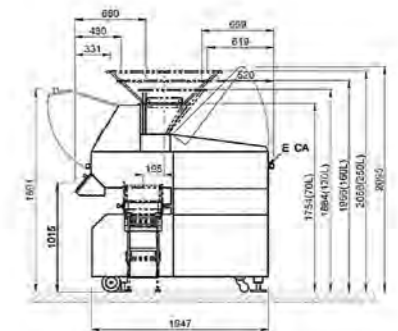
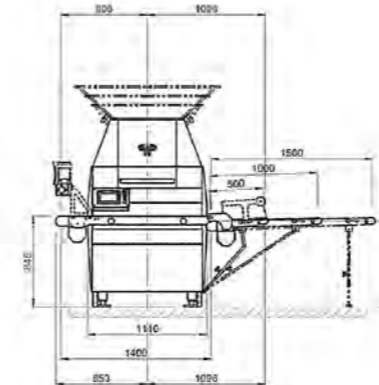
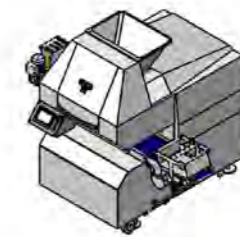
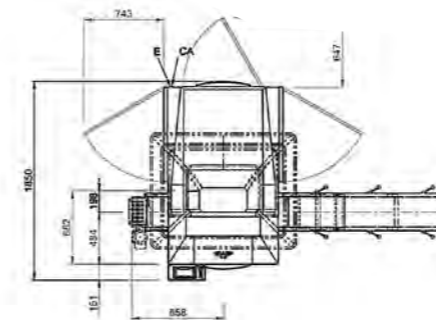

Illustration B 700