

think process!

WP Haton



B 300

Dough Divider

WP BAKERYGROUP

think process!

B 300

Picture B 300

SUITABLE FOR MOST COMMON TYPES OF DOUGH AS WELL AS SENSITIVE DOUGHS. THE DIVIDER HANDLES A BIG VARIETY OF DOUGH TYPES SUCH AS WHEAT, WHEAT/RYE, STIFF (PIZZA) DOUGHS, AS WELL AS SOFT (FRENCH) DOUGHS.



BENEFITS

- Robust design
- Long lifespan by using wear-resistant materials
- Minimum oil consumption
- Dough friendly dividing at high capacity
- High weight precision
- Self-cleaning knife
- Position stop for easy cleaning
- Suction volume adjustable
- Wear-resistant dividing system with Ni-Resist dividing unit
- Solid construction of drive unit and dividing system
- Hinged hopper for easy cleaning
- Easy access for cleaning and maintenance

BASIC EXECUTION:

- 1 pocket machine
- Dividing unit with automatic oiling on unit, 6 fixed dosing valves / oil tank 5 litre
- Discharge conveyor straight, L=1435 mm
- Hopper stainless steel, 95 litre, with safety ring
- Operation: on / off / emergency stop / position stop
- Main piston, dividing chamber and hopper base: wear-resistant chrome nickel alloy
- Hopper base with Teflon coating
- Manual weight adjustment with read-out
- Measuring piston in food safe bronze
- Knife made of stainless steel, hardened
- Cover plates stainless steel, brushed, with Schmersal safety switches
- Frame steel, nickel plated
- Crankshaft and drive rods cast iron, nickel plated
- Undercarriage 2 rigid + 1 swivel castor with brake

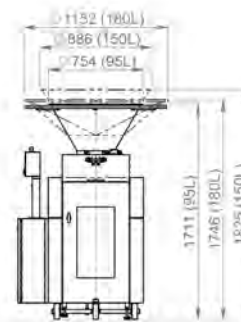
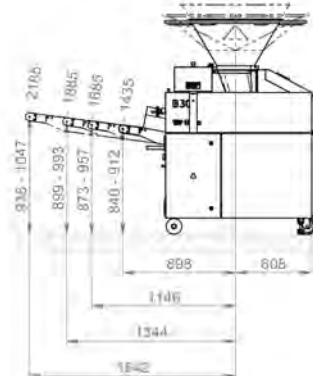
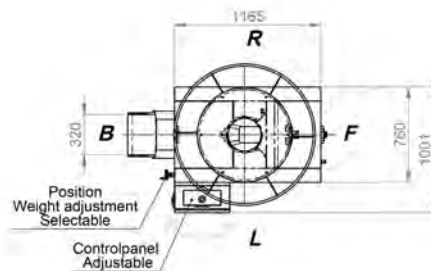
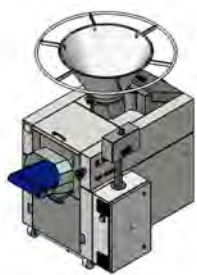

Illustration B 300

B 300

TYPE	WEIGHT RANGE	CAPACITY (FIXED)	CAPACITY VARIABLE (OPTION)
1000	100 - 1200 gr	510, 650, 725, 810, 910, 1010, 1130 or 1270 pcs/h.	507 - 1160 pcs/h.
1500	200 - 1800 gr		637 - 1456 pcs/h.
2000	400 - 2400 gr		700 - 1600 pcs/h.
DIMENSIONS (DEPENDING ON EXECUTION)		WEIGHT	CONNECTED LOAD
Length	1610 mm	net 720 kg	230/400 V, 3 phase, 50 Hz + earth
Width	1010 mm	gross 880 kg	1,8 KVA
Height	1720 mm	Shipping volume 2,6 m ³	

OPTIONS B 300

- Hinged hopper stainless steel 150 litre, without safety ring
- Hopper inside Teflon coated for round hoppers 95 and 150 litre
- Hinged hopper stainless steel 180 litre, inside Teflon coated, without safety ring
- Hopper base Nedox coated
- Oiling on hopper including oil shortage signalisation
- Oil shortage signalisation
- Siemens touch panel : Pre-set counter
- Siemens touch panel : Servo weight adjustment with digital read-out, digital pieces counter
- Siemens touch panel : Recipe control (only in combination with servo weight adjustment and/or frequency inverter)
- Siemens touch panel: Frequency inverter for variable speed
- Discharge conveyor straight, 1685, 1885 or 2185 mm
- Beka pump 8 P, lubrication on dividing unit and conveyor
- Mechanical flour duster
- Pressure board on discharge conveyor
- Oiling on measuring piston
- Mechanical discharge flap with plastic scraper
- Height machine increased by 100 mm
- Customer specific Blue Box

WP BAKERY GROUP USA

1 Enterprise Drive, Suite 408 | Shelton, CT 06484 // Phone 203-929-6530 // Fax 203-929-7089
 info@wpbakerygroupusa.com // www.wpbakerygroupusa.com