

## BOB 3000

TYPE	WEIGHT RANGE	CAPACITY
BOB 3000	<2200 gr	<3000 pcs/h. depending on weight and recipe

DIMENSIONS		WEIGHT	CONNECTED LOAD
Length	3264 mm	nett .....kg	230/400 V 3 ph 50 Hz
Width	800 mm	gross.....kg	drive moulding belt 2x 0,75 kW
Height	1920 mm		drive discharge belt 0,37 kW
			drive flour duster 0,12 kW

### OPTIONS

- Second flour duster
- Discharge conveyor executed as positioning / step belt
- Customer specific Blue Box

#### WP BAKERY GROUP USA

2 Trap Falls Road, Suite 105, Shelton, CT 06484 // Phone 203-929-6530 // Fax 203-929-7089  
 info@wpbakerygroupusa.com // www.wpbakerygroupusa.com



# BOB 3000

## Industrial Belt Rounding Machine

# BOB 3000

Picture BOB 3000

DEVELOPED ESPECIALLY FOR BREAD LINES WITH HIGH CAPACITIES, MANY PRODUCTION HOURS AND A HIGH DEGREE OF AUTOMATION. THE BELT ROUNDER CAN BE USED FOR THE PRODUCTION OF ROUND DOUGH PIECES MADE OUT OF WHEAT, RYE OR OTHER DOUGHS WITH A LOW GLUTEN CONTENTS OR VERY STICKY DOUGHS. BOB 3000 HANDLES DOUGH WEIGHTS UP TO 2200 GR. WITH AN OUTPUT UP TO 3000 PCS/HR.



## BENEFITS

- Frequency regulated belt speeds for variable rounding characteristics
- Quick lock adjustment of the belts for easy cleaning
- 3 way adjustment of the rounding path - bottom path (by opening the V belt) - top (by opening the angle) - middle V (by adjusting the insert pieces)
- Use of plastic materials for easy cleaning
- Frame and other important parts out of stainless steel
- Flour duster frequency inverter and integrated dough detector
- Discharge conveyor can be used as positioning belt - option
- Plastic containers underneath belt rounder path
- The BOB 3000 is movable
- Rounding path is approx. 3 mtr.

## BASIC EXECUTION:

- Frame stainless steel
- 2 felt belts in V shape
- 1 fixed speed for one belt / one belt driven by frequency inverter
- 1 flour duster with frequency inverter
- Quick lock adjustment of belts
- Rounding path can be adjusted by opening the angle of the belts, top and bottom as well as adjusting the inserts
- Discharge conveyor with fixed speed
- Rounding path 3000 mm

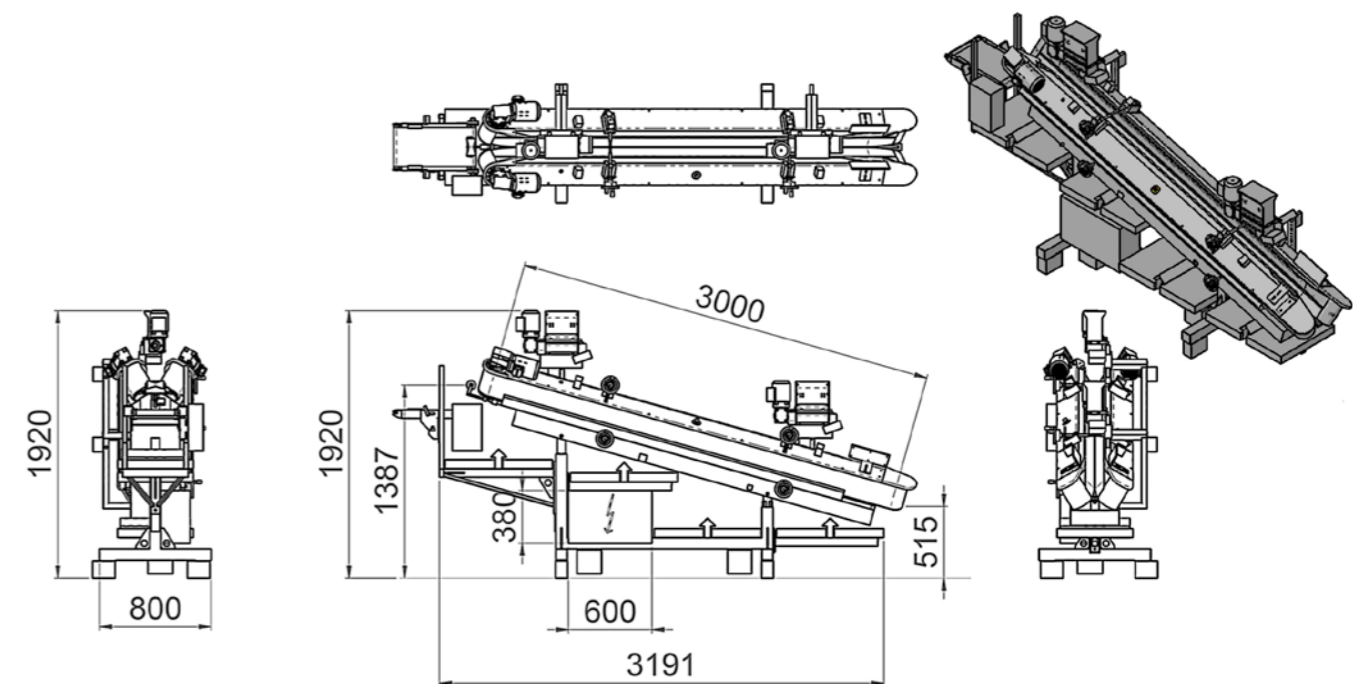

Illustration BOB 3000