

think process!



Werner & Pfleiderer
Bakery Technologies

SELECTA MODULAR

The best roll baking system
for artisan bakers



WP BAKERYGROUP

QWP

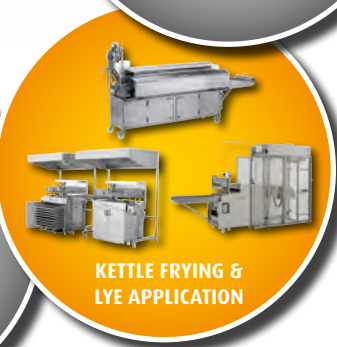

Artisanal bakeries just as well as industrial large-scale bakeries worldwide rely on WP BAKERYGROUP as the leading provider of machines and systems that cover the entire process chain.

The corporation covers all areas of bakery technology with utmost professional competence. Many of the WP group companies have been market leaders in their respective field for decades, if not for centuries. They develop innovative technical solutions with their know-how with only one goal: help bakeries achieve the best quality baking results in terms of economics and energy-efficiency.

WP Werner & Pfleiderer Bakery Technologies

WP Bakery Technologies has set the standards in terms of baking technology for more than 135 years. Countless patents and the high reputation enjoyed by the pioneering technology worldwide provide ample proof for it.

When bakers are asked why they rely on machines from WP, the answer is clear. It is the technology for best quality baked goods and it offers always added value. The SELECTA MODULAR and its sophisticated modular system is a good example of this.



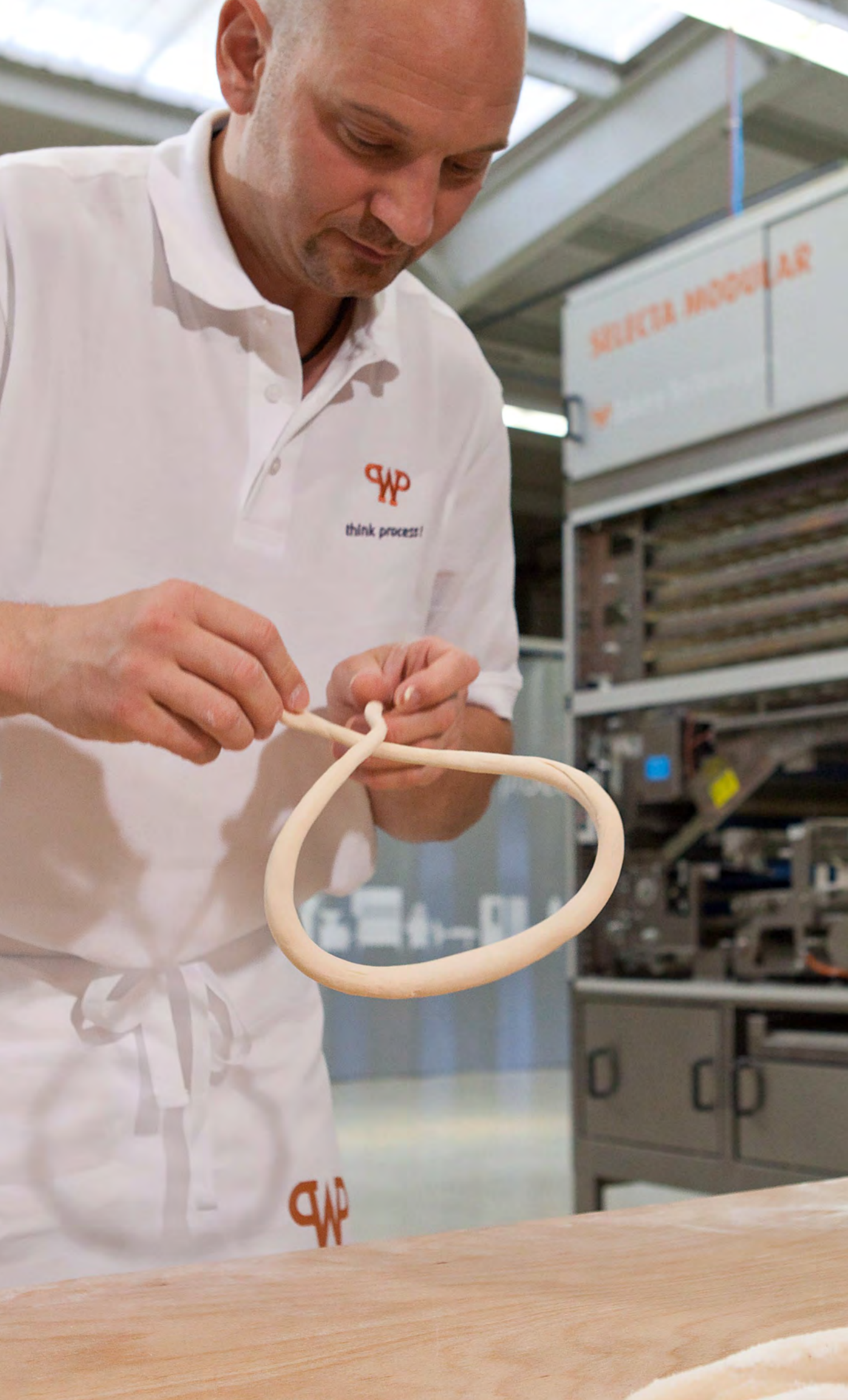

WP

think process!

SELECTA MODULAR

WP

SELECTA MODULAR

Technology for your individual needs

Gentle on the dough, flexible, hygienic – the modular design of the **SELECTA MODULAR**:

- All components are individually selectable
- The system is subsequently flexibly expandable





Maximum flexibility for every need



This is the success principle of the **SELECTA MODULAR**. You choose exactly the modules you currently need for your product range. Expand the system with further modules or external units, as required.

- Optional modules
e.g. seeding, angle cutting station, external depositing unit, etc.
- Automation with ROBOMATIC tray loading robot

SELECTA MODULAR allows you to react to changing market requirements at any time, to always keep your product range attractive and to produce individual baked goods.



The three versions of the **SELECTA MODULAR**



SELECTA MODULAR FORM for formed rolls such as Kaiser rolls, star rolls, button rolls, and many more

Modules: Basic module + stamping unit + depositing unit + power cabinet

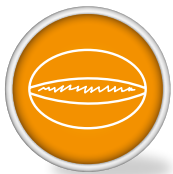

SELECTA MODULAR ROLL for slit rolls, long-rolled products, cut rounds, and many more

Modules: Basic module + long roller + cutting unit + depositing unit + power cabinet



SELECTA MODULAR KOMBI for the largest variety of formed and rolled bakery items

Modules: Basic module + stamping unit + long roller + cutting unit + depositing unit + power cabinet





GENTLE ON THE DOUGH AND ACCURATE DIVIDING



The right head machine makes your system perfect.

A gentle dough dividing and moulding process has a decisive effect on the quality of your end products. No doubt about it. However, since no two bakery businesses are the same, we combine the **SELECTA MODULAR** with a head machine that is equally gentle on the dough and flexible: the **MULTIMATIC**. It is available in several versions – tailored to meet your needs.

THE ADVANTAGES OF THE MULTIMATIC

- **Extended weight range:** thanks to double piston system
- **Most gentle dough handling:** thanks to gentle drum moulding system, adjustable moulding belt, variable feed pressure
- **Hygiene:** consistent separation of dough-handling parts from the drive mechanism
- **Easy to clean:** machine easily accessible and all dough-handling parts removable
- **Practical hopper:** holding capacity 40 kg



THE PERFORMANCE RANGES OF THE MULTIMATIC

■ MULTIMATIC C / CG

Weight range 25 g to 150 g

Maximum hourly output approx. 2,000 pieces per row

■ MULTIMATIC S / SG / SGR

Weight range 25 g to 200 g

Maximum hourly output approx. 2,000 pieces per row



SELECTA MODULAR FORM

Stamped rolls in best craftsmanship quality

The **SELECTA MODULAR FORM** is the optimum baking system for small bakery items for round, stamped products of infinite variety.



Kaiser roll



Star roll



Button roll



Dinner roll



Football roll



Smooth round roll
(Berliner)



Kringel roll



Kärntner roll



Double roll



Pressed roll



THE HIGHLIGHTS

- Hourly output from 4,500 to 9,000 pieces
- For best quality bakery items: pre-proofing time 8 to 16 minutes
- Revolver stamping head for stamping tools with maximum 4 rows of tools
- Individually expandable through exchange rails
- Green mode/direct depositing
- Maintenance-free hanger
- Array of options (e.g. hygiene stamping cups, etc.)
- Exchangeable hanger ribbons made from polyester felt as standard

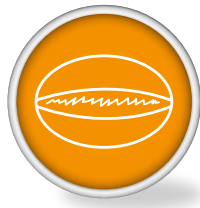

SELECTA MODULAR ROLL

Long-rolled products in attractive diversity

Slit rolls, baguette rolls, Krustis, bread sticks,... the range of cut and/or long-rolled products that can be produced on the **SELECTA MODULAR ROLL** is almost infinite.



Slit roll



Long-rolled products in/bread sticks



Cut round roll



Smooth round roll (Berliner)

THE HIGHLIGHTS

- Hourly output from 3,600 to 9,000 pieces
- For best quality bakery items: pre-proofing time 8 to 16 minutes
- Easily exchangeable pressure boards (optional)
- Various modules for long rolling, pressing, endless long rolling and folding (optional)
- Various exchangeable modules (optional)
- Green mode/direct depositing
- Maintenance-free hanger
- Array of options (e.g. hygiene stamping cups, etc.)
- Exchangeable hanger ribbons made from polyester felt as standard







SELECTA MODULAR KOMBI



The ultimate variety of rolls

Your imagination knows no boundaries! The **SELECTA MODULAR KOMBI** unites all the advantages of the **SELECTA MODULAR FORM** and **ROLL**. Expand your range of rolls with individual and varied products. You can hardly set yourself apart from the competition more positively.

THE HIGHLIGHTS

- Hourly output from 3,600 to 9,000 pieces
- For best quality bakery items: pre-proofing time 8 to 16 minutes
- Easily exchangeable pressure boards (optional)
- Revolver stamping head for stamping tools with maximum 4 rows of tools, individually expandable through exchange rails
- Various exchangeable modules (optional)
- Variety of modules for long rolling, pressing, folding, etc.
- Green mode/direct depositing possible
- Array of options (e.g. hygiene stamping cups, etc.)
- Exchangeable hanger ribbons made from polyester felt as standard
- Maintenance-free hanger



Kaiser roll



Star roll



Button roll



Dinner roll



Football roll



Smooth round roll
(Berliner)



Kringel roll



Kärntner roll



Double roll



Pressed roll



Slit roll



Plaits



Cut round roll



Smooth round roll
(Berliner)



Long-rolled products/
bread sticks



Styrian long roll





WP **NAVIGO II** PROFI-CONTROL

Everything under control!

Easy to operate, production-reliable and available at all times – everything you ask of a fully automatic control system.

The **WP NAVIGO II PROFI-CONTROL** meets these requirements to the fullest.

YOUR ADVANTAGES:

- Large touch screen display
- Easy and safe operation
- Reproducible quality and high level of production reliability
- Freely programmable depositing unit
- Networking and efficient remote diagnosis as well as remote maintenance possible
- Data backup to flash card or USB flash drive
- Master control (password protected)



WP SmartControl

Usability, production reliability and high degree of availability – this is what WP SmartControl stands for. In practical terms, this means: WP machines and equipment are easy to use, feature identical menu-assisted operation with uniform icons, colors, and procedures and provide powerful, secure remote diagnosis and maintenance, upon request.

SELECTA MODULAR OPTIONS



THE OPTIONS ARE YOURS!

The clever modular design of the **SELECTA MODULAR** applies for the optional choices. The wide choice of modules allows you to turn the roll baking system into the multi-function machine you need for your business.

1 HANGER RIBBONS

Four different hanger ribbons made from high-quality polyester fabric as standard, optionally made of gauze, felt or canvas

2 FINAL PROOFING CABINETS

Final proofing cabinets in different versions

3 HEATING AND MOISTENING

7 EXTERNAL UNITS

Attachment of external units: seeding, multi long roller, angle cutting unit, external depositing unit, ROBOMATIC tray loading robot, etc.





4 LATERAL DISCHARGE

Transfer to lateral discharge, e.g. for pretzels or to a curling machine



6 MOVABLE

System on wheels (wheel frame)

5 PRESSURE ROLLER ABOVE SPREADING BELT

8 DOUGH DIVIDER AND MOULDING MACHINE

MULTIMATIC or TEWIMAT head machine in many configurations

9 HYGIENE

Variety of hygiene options

SELECTA MODULAR

MAXIMUM FLEXIBILITY



Technology for your individual needs

Gentle on the dough, flexible, hygienic – the modular design of the **SELECTA MODULAR**:

- All components are individually selectable
- The system is subsequently flexibly expandable



2 SELECTA MODULAR FORM STAMPING MODULE

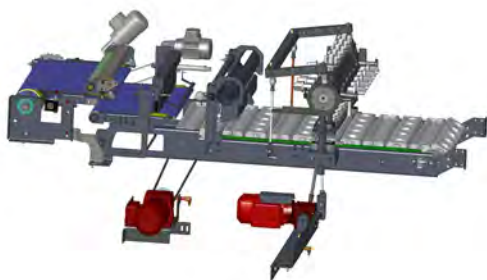

3 SELECTA MODULAR KOMBI STAMPING AND CUTTING MODULE



4 SELECTA MODULAR ROLL CUTTING MODULE

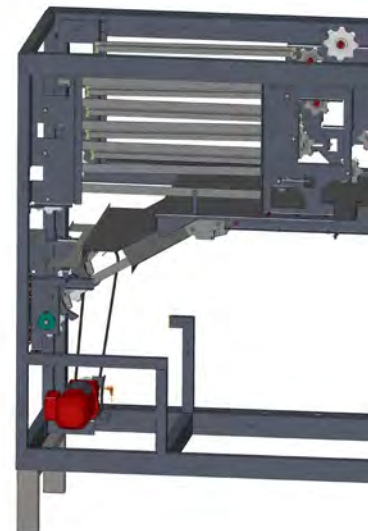

1 BASIC MODULE



10 POWER MODULE PRE-PROOFING CABINET

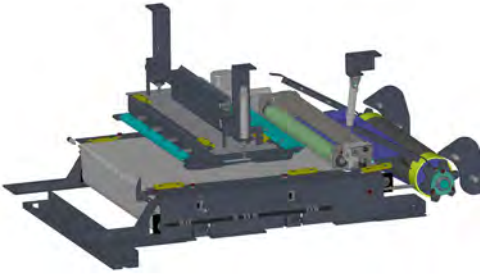

5 LONG ROLLER

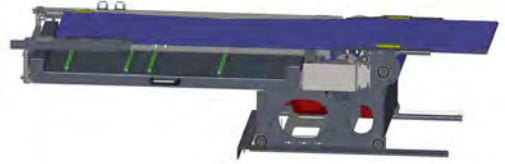

6 DEPOSITING UNIT

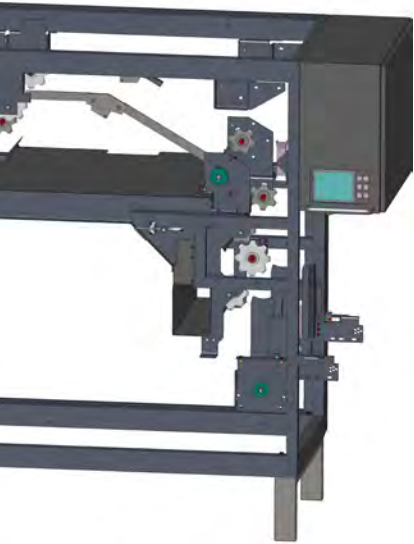

7 POWER MODULE
PRE-PROOFING CABINET



8 POWER MODULE
PRE-PROOFING CABINET

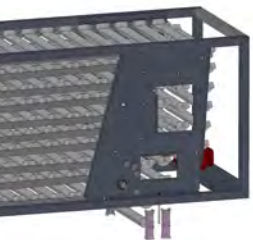

INET



9 POWER MODULE
PRE-PROOFING CABINET



MAXIMUM PERFORMANCE FLEXIBILITY FOR EVERY NEED



PRODUCT VARIETY THAT GROWS

With the **SELECT MODULAR** you can create an exceptionally wide variety of products – thanks to the modular design. The modular system design is beneficial when it comes to the performance range. Select the performance you need today. If your production increases, the system can be easily expanded. With the **SELECTA MODULAR** you are totally flexible in the future!

PERFORMANCE THAT GROWS

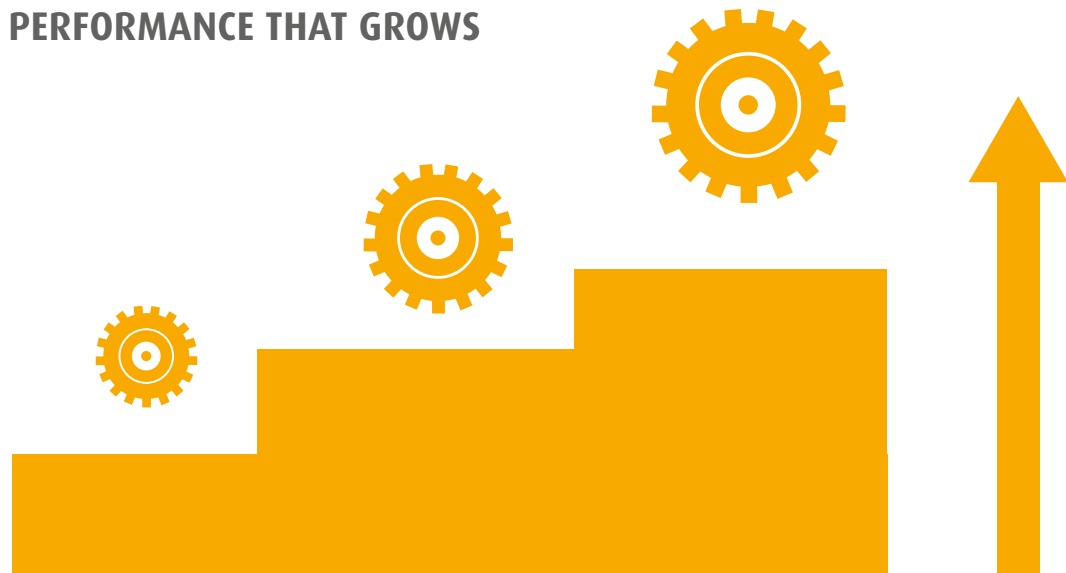



VARIABLE IN PERFORMANCE

- 3 to 6-row
- Weight range from 35 g to 150 g (depending on configuration)
- Hourly output up to 9,000 pieces
- For tray dimensions of 600 x 400/600 x 800/600 x 1,000 mm
- System available in width of 600 and 800



HYGIENE

A clean affair!



WP CleanTec

Dirt should not accumulate in the first place. If it cannot be avoided, it must be easy to detect and to remove. This is the concept of WP CleanTec. It is foresighted designs, clever machine details and innovative materials that help implement it – for maximum hygiene!

- All dough-handling parts can be removed for cleaning
- Hygiene stamping cups: Stamping cups washable up to 60 °C (option)
- High performance degermination station with double UV degermination (option)
- Hanger: Ribbons of high-quality, easy-drying polyester fabric, easily removable for cleaning with clip locks.
- System parts: Guide plates, casing, climate modules, long rolling and stamping tools, flour duster and exchangeable modules mountable resp. removable
- High ground clearance
- Plexiglas windows on both sides can be opened and removed

FOR YOU, THIS MEANS:

- Cleaning time reduced to a minimum
- High degree of practicability
- Maximum value retention
- Hygienic safety



SELECTA MODULAR CONCLUSION

You will be enthusiastic about this roll baking system!

THE MOST IMPORTANT FACTS AT A GLANCE

- Product-specific conditioning gentle on the dough for small bakery items in perfect craftsmanship quality
- Flexible, modular system design
- Configuration to suit individual requirements
- Variable capacity, subsequently expandable
- Automated production process with reproducible quality
- Maintenance-free hanger
- Automatic chain tensioner with electronic monitoring
- Depositing unit for proofing boards in the 3 Euro sizes



think process!



SOMETHING YOU CAN RELY ON!

One glance at the WP quality seals tells you the areas in which the WP machines excel.

WP BakingQuality

Sophisticated bakers expect machines and systems with which they are able to produce premium-quality baked goods. We call this technology WP BakingQuality.



WP SmartControl

Usability, production reliability and high degree of availability – this is what WP SmartControl stands for. In practical terms, this means: WP machines and equipment are easy to use, feature identical menu-assisted operation with uniform icons, colors, and procedures and provide powerful, secure remote diagnosis and maintenance, upon request.



WP GreenEnergy

Lowest possible energy consumption – maximum efficiency: we develop innovative technical solutions that conserve valuable energy resources, that are less environmentally harmful and that reduce energy costs of bakeries with this requirement in mind.



WP CleanTec

Dirt should not accumulate in the first place. If it cannot be avoided, it must be easy to detect and to remove. This is the concept of WP CleanTec. It is foresighted designs, clever machine details and innovative materials that help implement it – for maximum hygiene!



WP Blue Value

WP Blue Value ensures with comprehensive service and support that your machinery runs continuously and operationally reliable over the entire life cycle.



think process!

BAKERYGROUP

 Kemper

 Haton

 Winkler

 Riehle

 Werner & Pfleiderer
Bakery Cooling

 Werner & Pfleiderer
Bakery Technologies

 Werner & Pfleiderer
Instore Baking

 Werner & Pfleiderer
Industrial Bakery Technologies

 Green

 Werner & Pfleiderer
Bakery Service

WP BAKERY GROUP USA

2 Trap Falls Road, Suite 105 // Shelton, CT 06484 // Phone 203-929-6530 // Fax 203-929-7089
info@wpbakerygroupusa.com // www.wpbakerygroupusa.com